

Octal buffers (3-State)

74F244/74F244B

FEATURES

- Octal bus interface
- 3-State output buffer sink 64mA
- 15mA source current
- Guaranteed output skew less than 2.0ns (74F244B)
- Reduced ground bounce (74F244B)
- Reduced I_{CC} (74F244B)
- Reduced loading (74F244B I_{IL} = 40µA)
- Split lead frame offers increased noise immunity (74F244B)
- Industrial temperature range available (-40°C to +85°C) for 74F244
- 74F244 available in SSOP Type II package

DESCRIPTION

The 74F244 is an octal buffer that is ideal for driving bus lines of buffer memory address registers. The outputs are all capable of sinking 64mA and sourcing up to 15mA, producing very good capacitive drive characteristics. The device features two output enables, $\overline{OE}a$ and $\overline{OE}b$, each controlling four of the 3-State outputs.

The 74F244B is functionally equivalent to the 74F244. It has been designed to reduce effects of ground noise. Other advantages are noted in the features.

TYPE	TYPICAL PROPAGATION DELAY	TYPICAL SUPPLY CURRENT (TOTAL)
74F244	4.0ns	53mA
74F244B	4.0ns	33mA

ORDERING INFORMATION

DESCRIPTION	ORDER CODE		PKG DWG #
	COMMERCIAL RANGE V _{CC} = 5V ±10%, T _{amb} = 0°C to +70°C	INDUSTRIAL RANGE V _{CC} = 5V ±10%, T _{amb} = -40°C to +85°C	
20-pin plastic DIP	N74F244N, N74F244BN	I74F244N	SOT146-1
20-pin plastic SOL	N74F244D, N74F244BD	I74F244D	SOT163-1
20-pin plastic SSOP II	N74F244DB		SOT339-1

INPUT AND OUTPUT LOADING AND FAN OUT TABLE

PINS	DESCRIPTION	74F (U.L.) HIGH/LOW	LOAD VALUE HIGH/LOW
I _a n, I _b n	Data inputs (74F244)	1.0/2.67	20µA/1.6mA
	Data inputs (74F244B)	1.0/0.067	20µA/40µA
$\overline{OE}a, \overline{OE}b$	Output enable inputs (active low) (74F244)	1.0/1.67	20µA/1.0mA
	Output enable inputs (active low) (74F244B)	1.0/0.067	20µA/40µA
Y _a n, Y _b n	Data outputs	750/106.7	15mA/64mA

NOTE: One (1.0) FAST unit load is defined as: 20µA in the high state and 0.6mA in the low state.

PIN CONFIGURATION

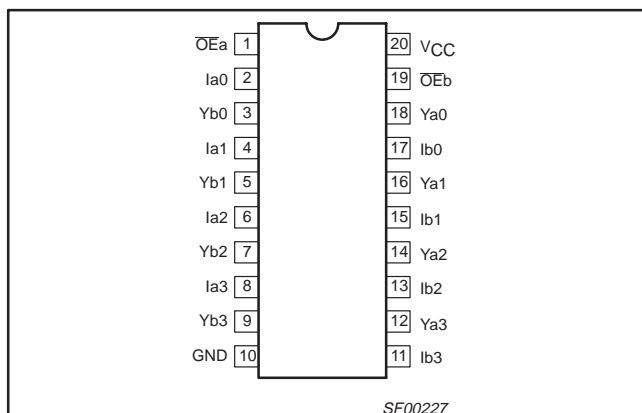

LOGIC SYMBOL

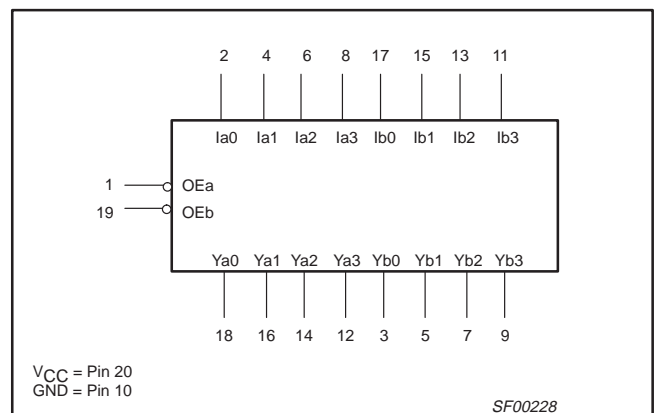

Octal buffers (3-State)

74F244/74F244B

ABSOLUTE MAXIMUM RATINGS

(Operation beyond the limit set forth in this table may impair the useful life of the device. Unless otherwise noted these limits are over the operating free air temperature range.)

SYMBOL	PARAMETER		RATING	UNIT
V _{CC}	Supply voltage		-0.5 to +7.0	V
V _{IN}	Input voltage		-0.5 to +7.0	V
I _{IN}	Input current		-30 to +5	mA
V _{OUT}	Voltage applied to output in high output state		-0.5 to V _{CC}	V
I _{OUT}	Current applied to output in low output state		128	mA
T _{amb}	Operating free air temperature range	Commercial range	0 to +70	°C
		Industrial range (74F244 only)	-40 to +85	°C
T _{stg}	Storage temperature range		-65 to +150	°C

RECOMMENDED OPERATING CONDITIONS

SYMBOL	PARAMETER	LIMITS			UNIT
		MIN	NOM	MAX	
V _{CC}	Supply voltage	4.5	5.0	5.5	V
V _{IN}	High-level input voltage	2.0			V
V _{IL}	Low-level input voltage			0.8	V
I _{IK}	Input clamp current			-18	mA
I _{OH}	High-level output current			-15	mA
i _{ol}	Low-level output current			64	mA
T _{amb}	Operating free air temperature range	Commercial range	0	+70	°C
		Industrial range (74F244 only)	-40	+85	°C

Octal buffers (3-State)

74F244/74F244B

DC ELECTRICAL CHARACTERISTICS

(Over recommended operating free-air temperature range unless otherwise noted.)

SYMBOL	PARAMETER		TEST CONDITIONS ¹			LIMITS			UNIT	
						MIN	TYP ²	MAX		
V _{OH}	High-level output voltage		V _{CC} = MIN, V _{IL} = MAX,	I _{OH} = -3mA	±10%V _{CC}	2.5			V	
					±5%V _{CC}	2.7	3.4		V	
			V _{IH} = MIN	I _{OH} = -15mA	±10%V _{CC}	2.0			V	
					±5%V _{CC}	2.0			V	
V _{OL}	Low-level output voltage		V _{CC} = MIN, V _{IL} = MAX, V _{IH} = MIN,	I _{OL} = MAX	±10%V _{CC}			0.55	V	
					±5%V _{CC}		0.42	0.55	V	
V _{IK}	Input clamp voltage		V _{CC} = MIN, I _I = I _{IK}				-0.73	-1.2	V	
I _I	Input current at maximum input voltage		V _{CC} = MAX, V _I = 7.0V					100	μA	
I _{IH}	High-level input current		V _{CC} = MAX, V _I = 2.7V					20	μA	
I _{IL}	Low-level input current		74F244 $\overline{O}Ea, \overline{O}Eb$		V _{CC} = MAX, V _I = 0.5V			-1.0	mA	
			74F244 I _{an} , I _{bn}					-1.6	mA	
			74F244B all inputs					-40	μA	
I _{OZH}	Off-state output current, high-level voltage applied		V _{CC} = MAX, V _O = 2.7V					50	μA	
I _{OZL}	Off-state output current, low-level voltage applied		V _{CC} = MAX, V _O = 0.5V					-50	μA	
I _{OS}	Short-circuit output current ³		V _{CC} = MAX			-100		-225	mA	
I _{CC}	Supply current (total)		74F244		V _{CC} = MAX	I _{CCH}		40	60	mA
						I _{CCL}		60	90	mA
						I _{CCZ}		60	90	mA
			74F244B			I _{CCH}		20	30	mA
						I _{CCL}		50	70	mA
						I _{CCZ}		29	40	mA

NOTES:

- For conditions shown as MIN or MAX, use the appropriate value specified under recommended operating conditions for the applicable type.
- All typical values are at V_{CC} = 5V, T_{amb} = 25°C.
- Not more than one output should be shorted at a time. For testing I_{OS}, the use of high-speed test apparatus and/or sample-and-hold techniques are preferable in order to minimize internal heating and more accurately reflect operational values. Otherwise, prolonged shorting of a high output may raise the chip temperature well above normal and thereby cause invalid readings in other parameter tests. In any sequence of parameter tests, I_{OS} tests should be performed last.

Octal buffers (3-State)

74F244/74F244B

AC ELECTRICAL CHARACTERISTICS FOR 74F244

SYMBOL	PARAMETER	TEST CONDITION	A PORT LIMITS						UNIT	
			$T_{amb} = +25^{\circ}\text{C}$ $V_{CC} = +5.0\text{V}$ $C_L = 50\text{pF}$, $R_L = 500\Omega$			$T_{amb} = 0^{\circ}\text{C to } +70^{\circ}\text{C}$ $V_{CC} = +5.0\text{V} \pm 10\%$ $C_L = 50\text{pF}$, $R_L = 500\Omega$		$T_{amb} = -40^{\circ}\text{C to } +85^{\circ}\text{C}$ $V_{CC} = +5.0\text{V} \pm 10\%$ $C_L = 50\text{pF}$, $R_L = 500\Omega$		
			MIN	TYP	MAX	MIN	MAX	MIN		MAX
t_{PLH} t_{PHL}	Propagation delay I _{an} , I _{bn} to Y _n	Waveform 1	2.5 2.5	4.0 4.0	5.2 5.2	2.0 2.0	6.2 6.5	1.5 2.0	7.0 7.0	ns
t_{PZH} t_{PZL}	Output enable time to high or low	Waveform 2 Waveform 4	2.0 2.0	4.3 5.0	5.7 7.0	2.0 2.0	6.7 8.0	2.0 2.0	8.0 8.5	ns
t_{PHZ} t_{PLZ}	Output disable time from high or low	Waveform 2 Waveform 4	1.5 1.5	2.5 2.5	5.5 5.5	1.0 1.0	6.0 5.5	1.0 1.0	6.0 5.5	ns

AC ELECTRICAL CHARACTERISTICS FOR 74F244B

SYMBOL	PARAMETER	TEST CONDITION	LIMITS					UNIT
			$T_{amb} = +25^{\circ}\text{C}$ $V_{CC} = +5.0\text{V}$ $C_L = 50\text{pF}$, $R_L = 500\Omega$			$T_{amb} = 0^{\circ}\text{C to } +70^{\circ}\text{C}$ $V_{CC} = +5.0\text{V} \pm 10\%$ $C_L = 50\text{pF}$, $R_L = 500\Omega$		
			MIN	TYP	MAX	MIN	MAX	
t_{PLH} t_{PHL}	Propagation delay I _{an} , I _{bn} to Y _n	Waveform 1	2.5 2.5	4.5 4.5	5.7 6.0	2.0 2.5	6.2 6.5	ns
t_{PZH} t_{PZL}	Output enable time to high or low level	Waveform 2 Waveform 4	2.0 3.0	4.0 5.5	6.0 7.5	2.0 3.0	6.5 8.0	ns
t_{PHZ} t_{PLZ}	Output disable time from high or low level	Waveform 2 Waveform 4	1.5 1.5	2.5 2.5	5.5 5.5	1.0 1.0	6.0 5.5	ns
$t_{sk(0)}$	Output skew ^{1,2}	Waveform 3			1.5		2.0	ns

NOTES:

- $|t_{pN} \text{ actual} - t_{pM} \text{ actual}|$ for any output compared to any other output where N and M are either LH or HL.
- Skew times are valid only under same test conditions (temperature, V_{CC} , loading, etc.).

Octal buffers (3-State)

74F244/74F244B

SO20: plastic small outline package; 20 leads; body width 7.5 mm

SOT163-1

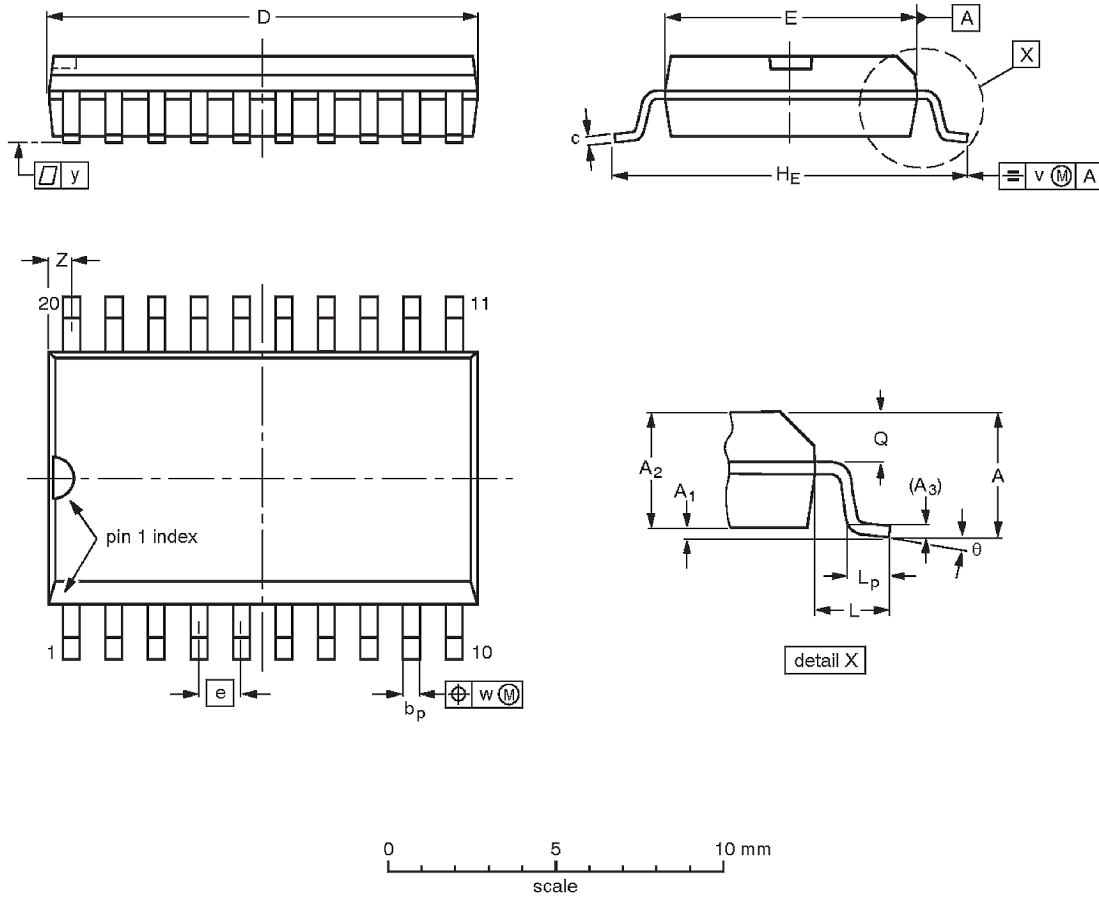

DIMENSIONS (inch dimensions are derived from the original mm dimensions)

UNIT	A max.	A ₁	A ₂	A ₃	b _p	c	D ⁽¹⁾	E ⁽¹⁾	e	H _E	L	L _p	Q	v	w	y	Z ⁽¹⁾	θ
mm	2.65	0.30 0.10	2.45 2.25	0.25	0.49 0.36	0.32 0.23	13.0 12.6	7.6 7.4	1.27	10.65 10.00	1.4	1.1 0.4	1.1 1.0	0.25	0.25	0.1	0.9 0.4	8° 0°
inches	0.10	0.012 0.004	0.096 0.089	0.01	0.019 0.014	0.013 0.009	0.51 0.49	0.30 0.29	0.050	0.42 0.39	0.055	0.043 0.016	0.043 0.039	0.01	0.01	0.004	0.035 0.016	

Note

1. Plastic or metal protrusions of 0.15 mm maximum per side are not included.

OUTLINE VERSION	REFERENCES				EUROPEAN PROJECTION
	IEC	JEDEC	EIAJ		
SOT163-1	075E04	MS-013AC			

Octal buffers (3-State)

74F244/74F244B

SSOP20: plastic shrink small outline package; 20 leads; body width 5.3 mm

SOT339-1

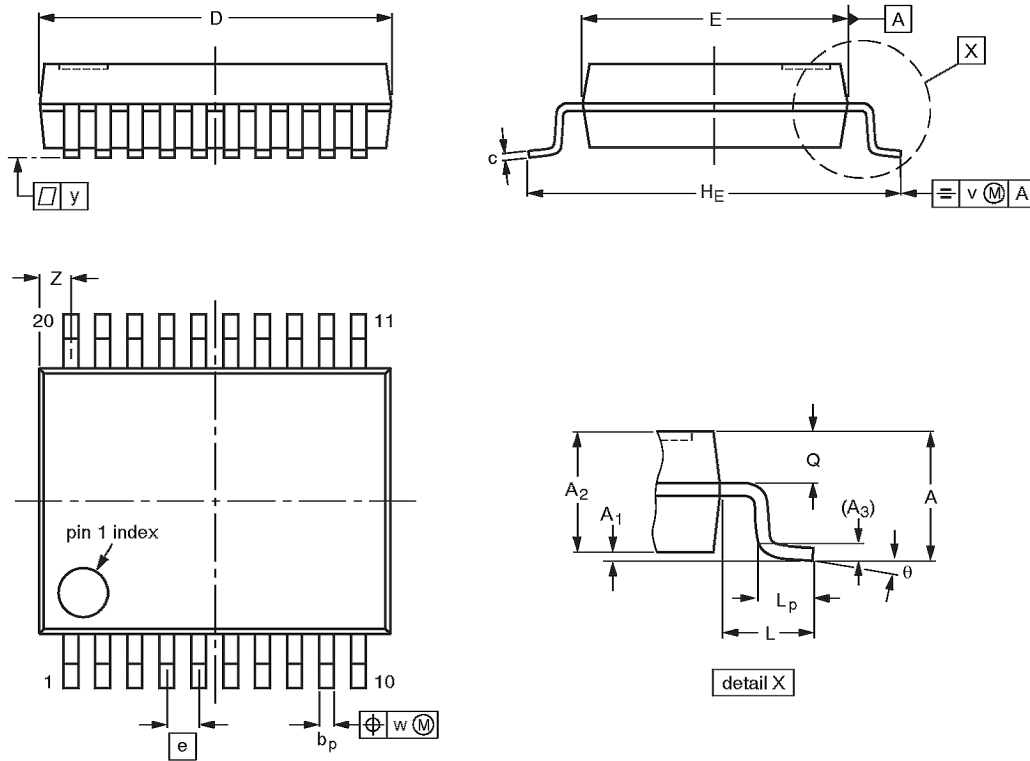

DIMENSIONS (mm are the original dimensions)

UNIT	A max.	A ₁	A ₂	A ₃	b _p	c	D ⁽¹⁾	E ⁽¹⁾	e	H _E	L	L _p	Q	v	w	y	Z ⁽¹⁾	θ
mm	2.0	0.21 0.05	1.80 1.65	0.25	0.38 0.25	0.20 0.09	7.4 7.0	5.4 5.2	0.65	7.9 7.6	1.25	1.03 0.63	0.9 0.7	0.2	0.13	0.1	0.9 0.5	8° 0°

Note

1. Plastic or metal protrusions of 0.20 mm maximum per side are not included.

OUTLINE VERSION	REFERENCES				EUROPEAN PROJECTION
	IEC	JEDEC	EIAJ		
SOT339-1		MO-150AE			